

GABIONS GALFAN & PVC COATED

Gabions

Gabions are baskets made of hexagonal woven wire Mesh Type 80, commonly referred to as double twist wire mesh as per SANS 1580:2005 (Figure 1 and Table 1). Gabions are filled with rock at the project site to form flexible, permeable, monolithic structures such as retaining walls, channel linings and weirs for erosion control projects.

The steel wire used in the manufacture of the gabion is heavily Galfan coated Class A per EN 10244-2 (Table 2). If required, a PVC coating is extruded over the Galfan wire to provide added protection for use in aggressive environments such as acidic soils and water, in salt water, in water carrying a high abrasive sediment load or wherever the risk of corrosion is present. The PVC coating has a nominal thickness of 0,5 mm. The tolerances of mesh and wire are shown in Tables 1 and 2.

In order to reinforce the structure, all mesh panel edges are selvaged with a wire having a greater diameter than the mesh wire. The gabion is divided into cells by means of diaphragms positioned at approximately 1m centres (Figure 1). Dimensions and sizes of Galfan and PVC coated gabions are shown in Table 3. When specifying Gabions in the tender documents or bill of quantities, please refer to Table 4.

Filling and Lacing

The Gabions must be filled with rock ranging between 100 mm and 250 mm. The range in sizes may allow for a variation of 5% oversize and / or 5% undersize rock, provided it is not placed at the exposed surface. In all cases, oversize rock shall not be larger than 300 mm and the undersize rock shall not be smaller than 100 mm. Rocks shall be hard, angular to round, durable and of such quality that they shall not disintegrate on exposure to water or weathering during the life of the structure. Care should be taken when placing the stone to ensure that the PVC coating on gabions is not damaged. All visible faces should be carefully hand placed for appearance purposes. For further information on the installation of gabions please refer to the [Installation Guidelines](#) for Gabions.

In place of lacing wire, lacing operations can be made by using a Spenax tool (Figure 4) available from our offices together with stainless steel rings (Figure 3A) having the following specifications:

- diameter: 3mm
- tensile strength: 156-178 kg/mm²

Spacing of the rings or loops must not exceed that shown in Figure 3B.

Wire

All tests on wire are performed prior to manufacturing the mesh.

1. **Tensile strength:** The wire used for the manufacture of the gabions has a tensile strength between 350-575 N/mm² according to SANS 675:1997.
2. **Elongation:** Elongation is not less than 10% in accordance with EN 10223-3. Tests are carried out on a sample at least 25 cm long.
3. **Galfan Coating:** Minimum quantities of Galfan (Table 2), meet the requirements of EN 10244-2 Table 2 and Class A.
4. **Adhesion of Galfan:** The adhesion of the Galfan coating to the wire shall be such that when the wire is wrapped six turns around a mandrel having four times the diameter of the wire, it does not flake or crack when rubbing it with the bare fingers.

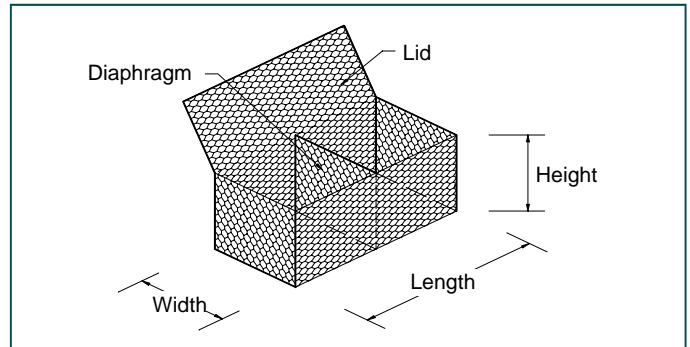

Figure 1

STANDARD MESH-WIRE			
Mesh Type 80	b	Tolerance (mm)	OD Wire Ø (mm)
Galfan	80	-4 +10	2,7
Galfan + PVC	80	-4 +10	2,7 / 3,7



MESH TOLERANCE

The tolerance on the opening of mesh "b" being the distance between the axis of two consecutive twists according to SANS 1580:2005.

Table 1

PROPERTIES OF WIRE				
Use	Units	Lacing	Mesh	Selvaged
Wire	Ø mm	2,2	2,7	3,4
Galfan		2,2 / 3,2	2,7 / 3,7	3,4 / 4,4
Galfan + PVC				
Wire Tolerance*	Ø mm	±0,08	±0,08	±0,1
Quantity of Galfan**	g/m ²	230	245	265
Tensile strength***	N/mm ²	350-575		

* According to SANS 675:1997

** According to EN 10244-2 Table 2 Class A

*** According to SANS 1580:2005 and SANS 675:1997

Table 2



Figure 2

PVC Coating Characteristics

The properties of the PVC material adheres to the following:

Colour: Grey RAL 7037 according to ASTM D1482-57T;

Specific gravity: 1,30-1,38 kg/dm³ in accordance with ASTM D792 Table 1;

Hardness: between 55 and 65 Shore D, according to ASTM D2240;

Tensile strength: not less than 20,6 MPa, according to ASTM D412-92;

Modulus of elasticity: not less than 18,6 MPa, in accordance with ASTM D412-92;

Abrasion resistance: the percentage of the weight loss is less than 12%, according to ASTM D1242-92;

Creeping corrosion: max. penetration of corrosion of the wire from a square cut end is 25 mm when the specimen has been immersed for 2,000 hrs in a 5% solution HCl (hydrochloric acid 12 Be).

The accelerated aging tests are:

Salt spray test: test period 3,000 hours, test method ASTM B117-94;

Exposure to UV rays: test period 3,000 hours at 63°C, test method ASTM D1499-92a and ASTM G23-93 apparatus Type E;

Brittleness temperature: no higher than -9°C, or lower temperature when specified by the purchaser, when tested in accordance with ASTM D746.

The properties after aging tests are as follows:

Appearance of coated mesh: no cracking, stripping or air bubbles, and no appreciable variation in color;

Specific Gravity: variations do not exceed 6%;

Hardness: variations do not exceed 10%;

Tensile strength: variations do not exceed 25%;

Modulus of elasticity: variations do not exceed 25%;

Abrasion resistance: variations do not exceed 10%;

Brittleness temperature: do not exceed +18°C.

STANDARD GABION SIZES		
Length (m)	Width (m)	Height (m)
1,0	1,0	1,0
1,5	1,0	1,0
2,0	1,0	1,0
3,0	1,0	1,0
4,0	1,0	1,0
2,0	0,5	0,5
2,0	1,0	0,5
3,0	1,0	0,5
4,0	1,0	0,5

Tolerances : Height, Width: ±5%; Length: ±10%
All sizes and dimensions are nominal.

Table 3

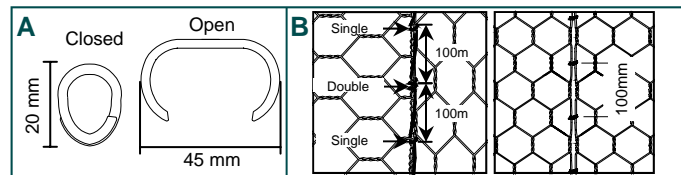

Figure 3

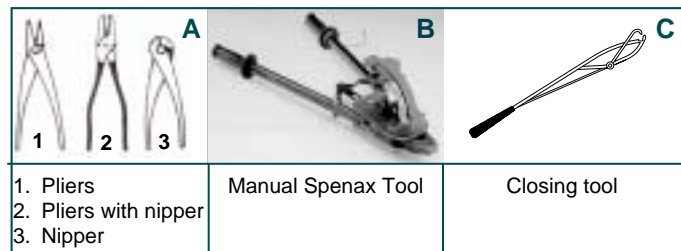

Figure 4

BILL OF QUANTITIES					
Item No.	Description	Unit	Quantity	Rate	Amount (R)
	GABIONS - SANS 1200DK:1995 (Double twist hexagonal wire mesh to SANS 1580:2005).				
1	GABIONS (Including material and delivery).				
1.1	Mesh Type 80 with 2,7mm Class A Galfan wire. Length x Width x Height	m ³			
1.2	Mesh Type 80 with 2,7 / 3,7mm Class A Galfan and PVC coated wire. Length x Width x Height	m ³			
2	Surface preparation for bedding of Gabions.	m ²			
3	Installation of Gabions (Including unfolding, placing, filling, lacing and bracing).	m ³			
4	Rockfill.	m ³			
5	Packing selected stone for exposed face.	m ²			
6	AG GEOTEXTILE (Including material, delivery, unrolling, cutting and placing). Continuous Polyester Filament Double Needle-Punched.				
6.1	AG150 - Minimum Energy Absorption of 4,0 kN/m	m ²			
6.2	AG200 - Minimum Energy Absorption of 6,5 kN/m	m ²			
6.3	AG300 - Minimum Energy Absorption of 10 kN/m	m ²			
6.4	AG400 - Minimum Energy Absorption of 12 kN/m	m ²			

Table 4